

KNAPHEIDE
SINCE 1848



COMBO BODIES

KNAPHEIDE COMBO BODIES



KNAPHEIDE COMBO BODY

By combining the practicality and versatility of the ever-popular Service Body (front) and Platform Body (rear), the Combo Body is an ideal solution for the needs of virtually any line of work nationwide. Multiple configurations of the Combo Body allow you to get the most practical upfit to meet your needs.

COMBO BODIES

At the crossroads of ingenuity and efficiency lies the Combo Body from Knapheide. Available configurations include DRW in 10' and 12' lengths, 40" tall side packs with flip tops, 46" and 60" tall side packs (no flip tops). See why professionals from multiple industries are choosing the Combo Body to handle the demands of their jobsites.

POPULAR VOCATIONS



CONSTRUCTION

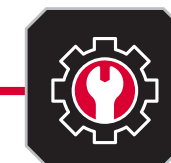

MUNICIPALITIES/
UTILITIES

A. COMBINATION OF OUR POPULAR SERVICE BODY AND PLATFORM BODY to provide optimal storage and transportation solutions

B. 10' OR 12' BODY FEATURES a 36" platform area partnered with a service body featuring 20" deep compartments. Upper compartments feature flip top for easy access

C. INTEGRATED LED S/T/T AND B/U, LED STROBE OPTION* with (8) selectable patterns and built-in reflectivity for additional safety**

*Additional wire harness required for strobe lights
**Covered under 3-year limited warranty

D. OVER-CAB MATERIAL RACK includes punched panel for visibility and safety

E. ALUMINUM DROP DOWN STAKE RACKS 12" or 18" high with split rear

F. UNDERDECK STORAGE COMPARTMENTS 10"Hx20"Dx36"L to maximize storage potential

G. AUTOMOTIVE-QUALITY, PADDLE-ACTIVATED ROTARY STYLE LATCHES make opening and closing easy, providing access to spacious side compartments

H. KNAPHEIDE (OR OEM) WHITE PAINT on exterior, compartment interiors, and cargo area of service body

I. CARGO AREA FEATURES TAILBOARD CHANNEL, E-TRACK, AND TIE DOWNS to help utilize and secure cargo. Channel accepts 2x6-2x10 boards to separate loads (not included)

J. CLASS V RECEIVER HITCH rated at 18,000 lb. max trailer weight and 3,600 lb. max tongue weight with 7-way flat trailer plug

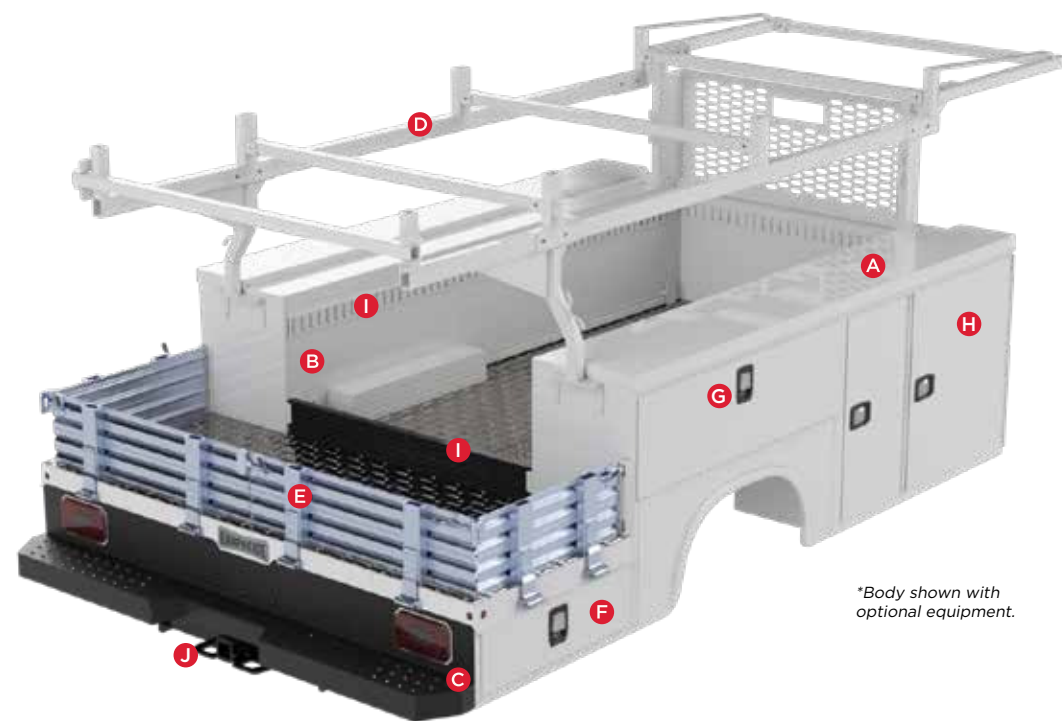

MODEL OPTIONS

MODEL	TYPE	LENGTH	HEIGHT	FLOOR WIDTH	COMPARTMENT DEPTH	WEIGHT
CB117D54	Standard	117"	40"	54"	20"	1,402 lb.
CB145D54	Standard	145"	40"	54"	20"	1,712 lb.
CB117D54F40	Flip Top	117"	40"	54"	20"	1,514 lb.
CB117D54H46	Standard	117"	46"	54"	20"	1,488 lb.
CB117D54H60	Standard	117"	60"	54"	20"	1,744 lb.
CB145D54F40	Flip Top	145"	40"	54"	20"	1,857 lb.
CB145D54H46	Standard	145"	46"	54"	20"	1,821 lb.
CB145D54H60	Standard	145"	60"	54"	20"	2,128 lb.
CB117D54F402MWD	Flip Top	117"	40"	54"	20"	1,514 lb.
CB145D54F402MWD	Flip Top	145"	40"	54"	20"	1,857 lb.
CB145D54H462MWD	Standard	145"	46"	54"	20"	1,821 lb.

Note: M = Master Lock, WD = Wheelhousing Delete

REQUEST A QUOTE



Visit knapheide.com/quote and fill out the form to receive a quote and additional product information.



POPULAR OPTIONS



POWER LOCKS



MASTER LOCKS



E-TRACK & ACCESSORIES



LED COMPARTMENT LIGHTS



ALUMINUM TREAD PLATE TRIM KITS



ALUMINUM DROP SIDE RACK SETS (12" AND 18")



UTILITY RACK



FRONT STROBE



CTECH DRAWERS

NOT PICTURED:

BUMPERS - GALVA GRIP WITH HITCH RECESS: WITH OR WITHOUT KNAPLINER

COMMITMENT TO CORROSION RESISTANCE

Corrosion won't be a concern when you buy quality Knapheide products. To give you the best corrosion protection, we utilize a state-of-the-art, custom-designed, 12-step, SST cathodic electrodeposition finishing system, called "E-Coat."

It bonds prime paint to steel by an electroplating process to give you a superior coat of primer, resulting in better corrosion protection compared to spraying methods.

This system allows us to create products with the highest level of corrosion resistance available.



FOLLOW US
LIKE US
TAG US



SIX YEAR, LIMITED TIME WARRANTY



**NO RUST
THROUGH**



**DOOR HINGES
WILL NOT FAIL OR
COME OFF BODY**



**LATCHES AND LOCK
CYLINDERS WILL NOT
FAIL TO OPERATE**



**SHELVES WILL NOT
BEND UNDER MAX.
LOAD OF 250 LBS.**

TO LEARN MORE VISIT
www.knapheide.com/warranty



NEVER SETTLE

If you are going to be a leader, it takes more than building a high-quality product. It means never being totally satisfied with that product, no matter how high quality it may be. It requires constant vigilance and a willingness to take a chance on something new. And it means exceeding expectations every time. As the industry changes, one thing never will—our commitment to making customers like you as productive and efficient as possible. We know you don't settle, and we don't either. That's why we want you never to settle for anything less than Knapheide on the back of your truck.

KNAPHEIDE. NEVER SETTLE.



The Knapheide Manufacturing Company
1848 Westphalia Strasse | Quincy, IL 62305
217-222-7131
www.knapheide.com